



# DC AMPERE AND VOLT METER

DC-24

## APPLICATIONS

Battery Charger

---

Solar Equipments

---

DC Motor Parameter Indications

---

Led Light Testing Panel

---

Extrusion Plants

---

# Mechanical Dimensions

## Body Dimensions

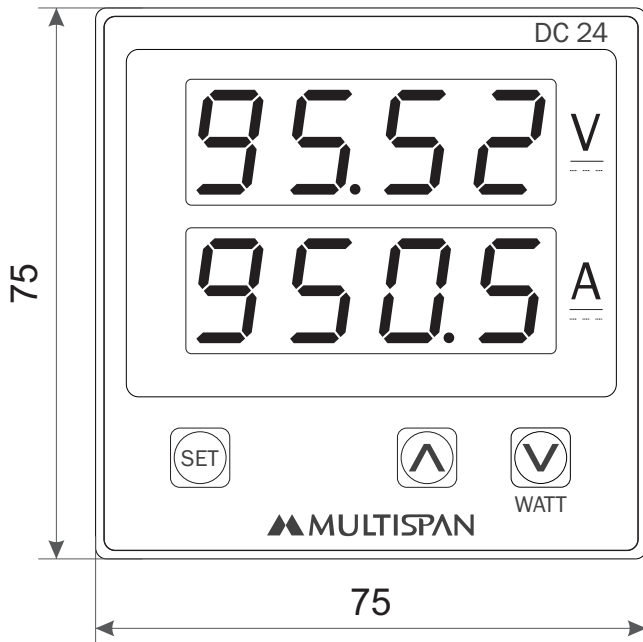

**FRONT VIEW**

All dimensions are in mm

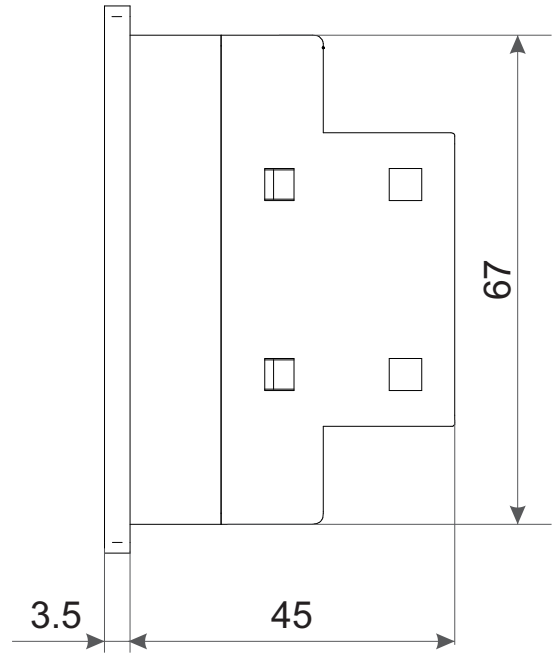

**RIGHT SIDE VIEW**

## Connection Diagram

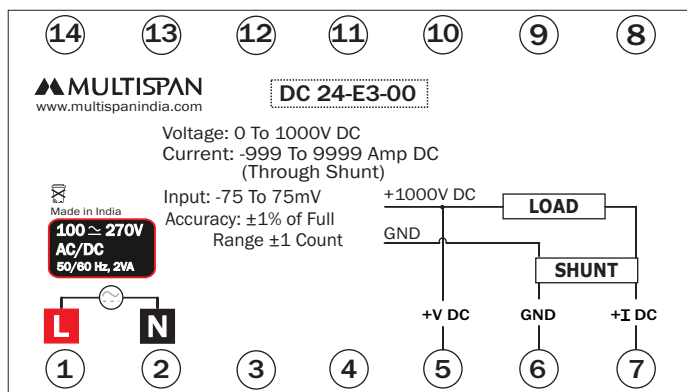

## Panel Cutout

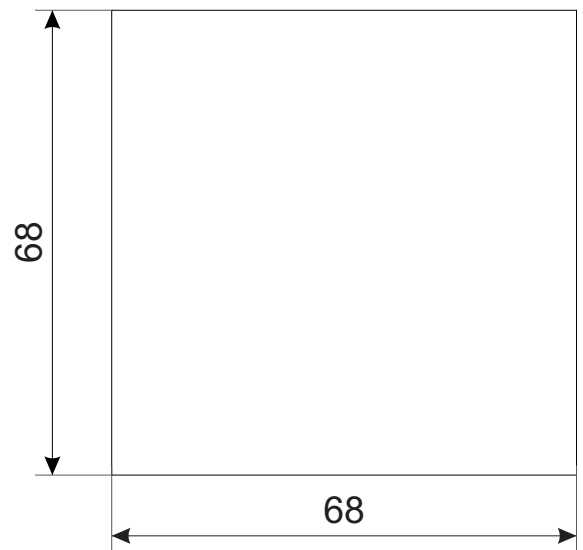

# TECHNICAL DATA

<b>Input Voltage</b>	0 to 1000V DC
<b>Input Current</b>	Through External Shunt (-75 to 75mV DC)
<b>Accuracy</b>	±1% of Full Range ± 1 Count

## Features

Shunt Selectable 5 to 9999 Ampere,  
Calculated Parameter : Voltage (0 to 1000V ),  
Current (0000 to 9999A DC)  
Through External Shunt,  
Watt (0000 to 9999 KW)

## Display & Keys

<b>Display</b>	<b>Upper</b>	4 Digit, 1Line 7 seg. 0.56" Red LED Display
	<b>Lower</b>	4 Digit, 1Line 7 seg. 0.56" White LED Display
<b>Key</b>	SET, INC, DEC/WATT	

## Input

### Voltage DC

<b>Direct Voltage</b>	0 to 1000V DC
<b>Burden</b>	<0.2 VA

### Current DC

<b>Current input</b>	Through External Shunt (-75 to 75mV DC)
<b>Burden</b>	<0.2 VA
<b>Current Range</b>	-999 to 9999

## Accuracy

±1% of Full Range ± 1 Count

## Environmental Characteristics

<b>Humidity</b>	95% RH Non-condensing
<b>Working Temperature</b>	0 to 55 °C
<b>Storage Temperature</b>	0 to 70 °C

## Calculated Parameters

	Range	Accuracy
<b>DC Voltage</b>	0.00 - 49.99 V DC	1 % OF 49.99V
	50.0 - 199.9 V DC	1 % OF 199.9V
	200.0 - 399.9 V DC	1 % OF 399.9 V
	400.0 - 1000 V DC	1 % OF 1000 V
<b>DC Current</b>	-999 - 9999A DC (1 % of FSD)	
<b>WATT</b>	0000 - 9999 KW (1 % of FSD)	

## Auxiliary Power Supply

<b>Power Supply</b>	100 to 270V AC/DC , 50/60Hz
<b>Burden</b>	3VA

## Mechanical Characteristics

<b>Mounting Type</b>	Panel Mount
<b>Dimension (HxWxD) mm</b>	75 x 75 x 45
<b>Panel Cutout (HxW) mm</b>	68 x 68
<b>Material</b>	<b>Front Enclosure</b> Polycarbonate (PC) ABS
<b>Terminal Screw Size</b>	M3.5
<b>Screw Torque (N.m)</b>	0.5
<b>Wire Gauge (AWG)</b>	26-14
<b>Weight (Approx) gms</b>	Unpacked : 225 Packed : 280
<b>Accessories</b>	1 Pair of Mounting Clamps